

Diversity Loop Interface Module

Installation Guide

Part no	Description
XPA-IN-14050-APO	Diversity Loop Interface Module

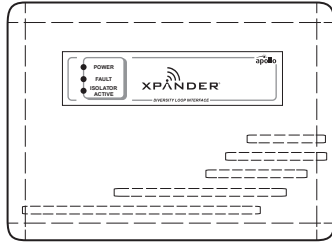

1 Pre installation



Installation must conform to applicable local installation codes and should only be installed by a fully trained competent person.

- Ensure the loop module is installed as per the site survey.
- Refer to step 3 to ensure optimised wireless performance.
- A maximum of 5 loop modules can be connected per loop.
- This device contains electronics that may be susceptible to damage from Electrostatic Discharge (ESD). Take appropriate precautions when handling electronic boards.

2 Components

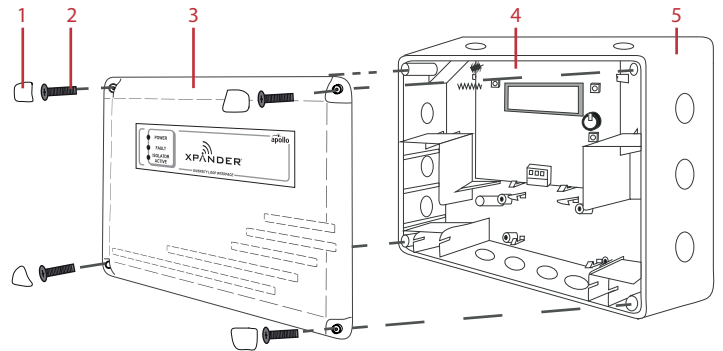

1 4x corner covers, 2 4x lid screws, 3 Loop module lid, 4 Loop module PCB, 5 Loop module back box

3 Mounting location guidelines



For optimum wireless performance, the following must be observed:

- Ensure the loop module is not installed within 2 m of other wireless or electrical equipment (not including the control panel).
- Ensure the loop module is not installed within 0.6 m of metal work.

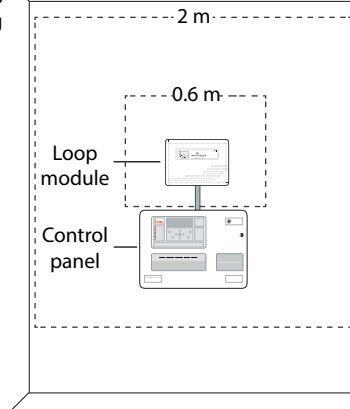

4 Optional PCB removal

- Remove the three circled retaining screws, before unclipping the PCB.

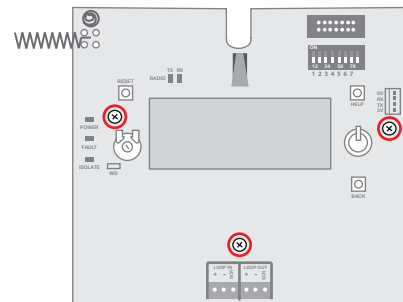

5 Remove cable entry points

- Drill the cable entry points as necessary.

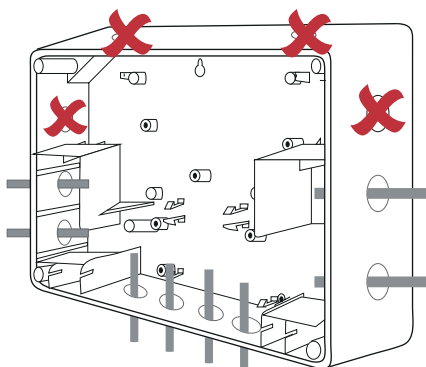

- = DO NOT use
- = Available cable entry points

6 Fix to the wall

- All five circled fixing positions are available for use as required.
- The key hole can also be used for locating and fixing where required.

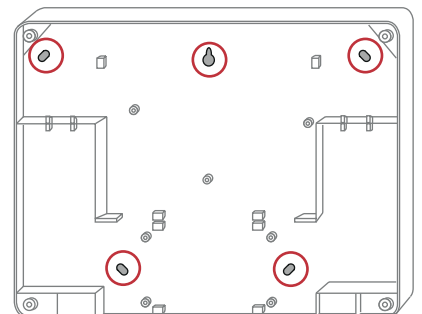

7 Connection wiring

- Loop cables should only be passed via the access points available.
- Flame retardant cable glands must be used.
- DO NOT leave excess cable inside the loop module.

Single loop module.

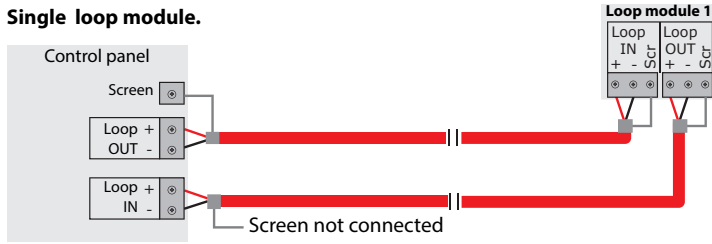

Multiple loop modules (max. 5)

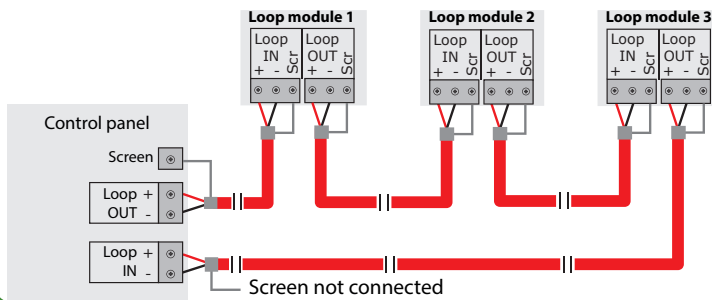

8 Configuration

- Set the loop module address using the on-board 8 way switch.
- Available selections are shown in the table below.

DIL SWITCH SETTING	DIL SWITCH SETTING	DIL SWITCH SETTING	DIL SWITCH SETTING	DIL SWITCH SETTING
Addr. 1.....8	Addr. 1.....8	Addr. 1.....8	Addr. 1.....8	Addr. 1.....8
1 10000000	11 11010000	21 10101000	31 11111000	41 10010100
2 01000000	12 00110000	22 01101000	32 00000100	42 01010100
3 11000000	13 10110000	23 11101000	33 10000100	43 11010100
4 00100000	14 01110000	24 00011000	34 01000100	44 00110100
5 10100000	15 11110000	25 10011000	35 11000100	45 10110100
6 01100000	16 00001000	26 01011000	36 00100100	46 01110100
7 11100000	17 10001000	27 10110000	37 10100100	47 11110100
8 00010000	18 01001000	28 00111000	38 01100100	48 00001100
9 10010000	19 11001000	29 10110000	39 11100100	49 10001100
10 01010000	20 00101000	30 01111000	40 00010100	50 01001100
51 11001100	61 10111100	71 11100010	81 10001010	91 11011010
52 00101100	62 01111100	72 00010010	82 01001010	92 00111010
53 10101100	63 11111100	73 10010010	83 11001010	93 10110100
54 01101100	64 00000010	74 01010010	84 00101010	94 01111010
55 11101100	65 10000010	75 11010010	85 10101010	95 11111010
56 00011100	66 01000010	76 00110010	86 01101010	96 00000110
57 10011100	67 11000010	77 10110010	87 11101010	97 10000110
58 01011100	68 00100010	78 01110010	88 00011010	98 01000110
59 11011100	69 10100010	79 11110010	89 10011010	99 11000110
60 00111100	70 01100010	80 00001010	90 01011010	100 00100110
101 10100110	106 01010110	111 11110110	116 00101110	121 10011110
102 00100110	107 11010110	112 00001110	117 10101110	122 01011110
103 11100110	108 00110110	113 10001110	118 01101110	123 11011110
104 00010110	109 10110110	114 01001110	119 11101110	124 00111110
105 10010110	110 01110110	115 11001110	120 00011110	125 10111110
				126 01111110

- The system can now be programmed.
- Refer to the XPander Commissioning Guide (PP2286) for details of compatible XPander devices and full programming information.

9 Apply power

Apply power to the control panel. The normal LED states for the Loop Module are as below:

- The green POWER LED will illuminate.
- The other LEDs should be extinguished.

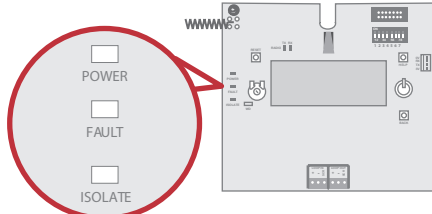

Status	Analogue Value
Cover removed	4
Quiescent	16
Background noise level too high	5
Background noise level medium	14
Background noise level high	13

10 Close loop module

- Ensure that the loop module PCB is correctly inserted and the PCB retaining screws are refitted.
- Refit the loop module lid, ensuring LEDs are not damaged by the light pipe when refitting.

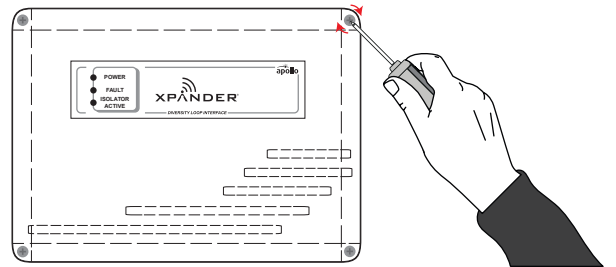

Specification

Operating temperature	-10 to +55 °C
Storage temperature	5 to 30 °C
Humidity	0 to 95% non-condensing
Operating voltage	17 to 28 VDC
Maximum loop current	15 mA at 24 VDC
Maximum loop impedance	50 Ω

Note: for isolator operation information see document PP2090, which is available upon request

IP rating	IP54
Operating frequency	868 MHz
Output transmitter power	0 to 14 dBm (0 to 25 mW)
Signalling protocol	X
Panel protocol	XP
Dimensions (W x H x D)	270 x 205 x 85 mm
Weight	0.95 kg
Location	Type A: For indoor use

Regulatory information

Manufacturing location Carrier Manufacturing Poland Sp. z o.o.
Ul. Kolejowa 24. 39-100 Ropczyce, Poland

Placed on the market by Apollo Fire Detectors Limited

Year of manufacture See devices serial number label

Certification



For detailed information, see the product Declaration of Performance (available at www.apollo-fire.co.uk).

Approved to

EN54-17:2005. Fire detection and fire alarm systems.
Part 17:Short-circuit isolators.

EN54-18:2005. Fire detection and fire alarm systems.
Part 18:Input/output devices.

EN54-25:2008. Incorporating corrigenda September 2010 and March 2012. Fire detection and fire alarm systems.

European Union Directives

Apollo declares that this device is in compliance with Directive 2014/53/EU. The full text of the EU declaration of conformity is available at the following internet address: www.apollo-fire.co.uk



2012/19/EU (WEEE directive): Products marked with this symbol cannot be disposed of as unsorted municipal waste in the European Union. For proper recycling, return this product to your local supplier upon purchase of equivalent new equipment, or dispose of it at designated collection points. For more information see www.recyclethis.info

Dispose of your batteries in an environmentally friendly manner according to your local regulations.