

GENERAL DESCRIPTION

EK-WL8-O is a wireless optical smoke sensor.

The device analyses the protected area for traces of smoke. An alarm condition is generated when the smoke level exceeds the threshold. The alarm signal is relayed to the Control Panel via the connected translator/expander modules.

The advanced design of the optical chamber guarantees a very high level of dust protection, effectively increasing the time between maintenance procedures.

The device is supplied with a mounting kit.

The product complies with the requirements of the EN54-7:2018 and EN54-25:2008 standards.



FEATURES

- Bi-directional wireless communication
- Intelligent algorithms
- Tamper switch
- 10-year battery life
- Self-optimizing wireless frequency and amplitude algorithms
- Patented smoke chamber design

GENERAL OVERVIEW

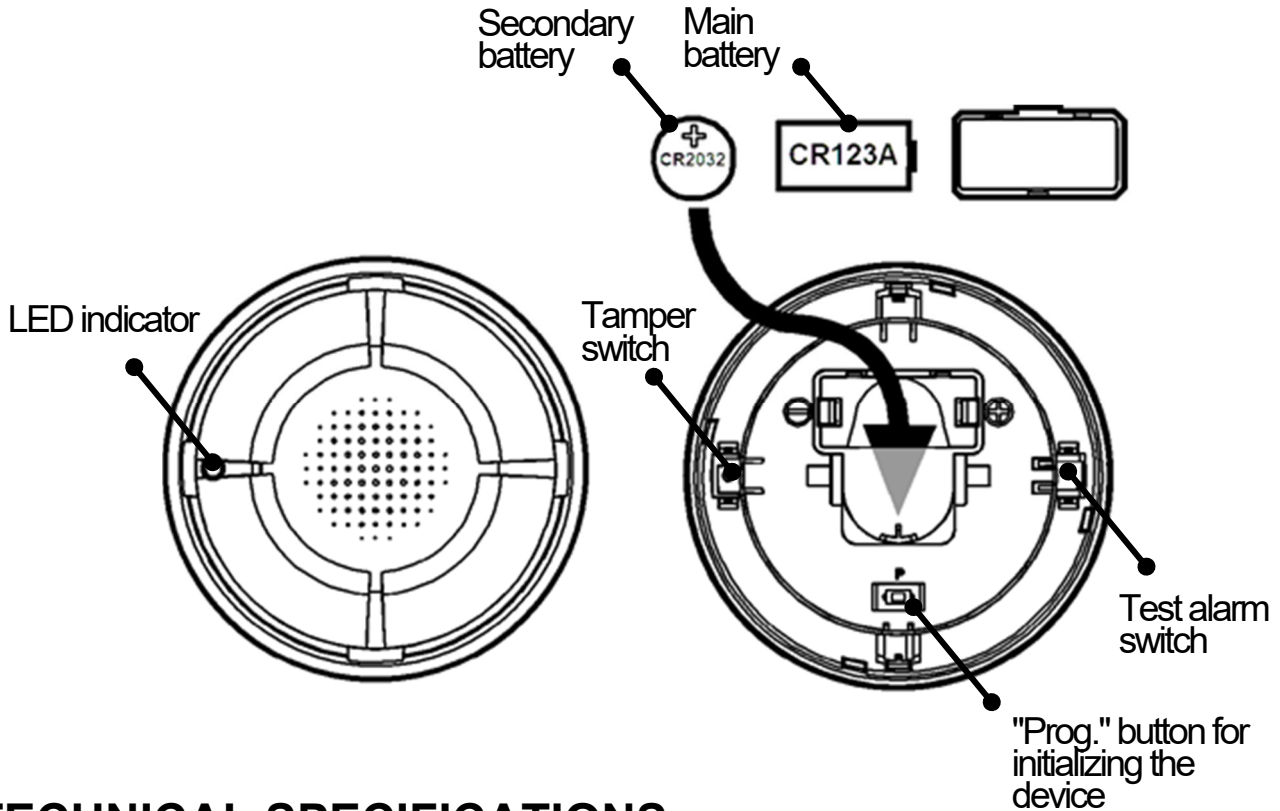

TECHNICAL SPECIFICATIONS

Communication range with a translator or expander	1200 m
Radio frequency	866 – 869.85 MHz
Modulation type	GFSK
Operating frequency channels	6
Radiated power	Not more than 25 mW
Receiver category (EN300-220-1)	1.5
Battery life:	
Primary battery (type CR123A)	8-10 years
Secondary battery (type CR2032)	Not less than 3 months (after primary battery low fault)
Dimensions (with the base)	111 mm x 57 mm
Weight	160 g
Max tolerated humidity	95% RH
Operating temperature range	From -10 °C to +55 °C

NOTE Check the latest version of the product specification document STFV.425238.033-E-PS for further data, obtainable from the manufacturer

PROGRAMMING

The “Prog.” button on the device is used for initializing the device in the system. Please refer to the translator manual for full instructions on how to add a device to the system. The device can also be initialized using the “Ekho Configuration” software.

INSTALLATION

In order to install the device, the mounting base should be fixed to the ceiling, the sensor can then be inserted into the base by rotating the sensor until it clips into the base.

Preferably, the device should be installed away from metallic objects, doors, and power lines, as they can cause the communication distance to drop. It is also important to avoid installing the device near electronic and computer equipment in order to protect it from potential electromagnetic interference.

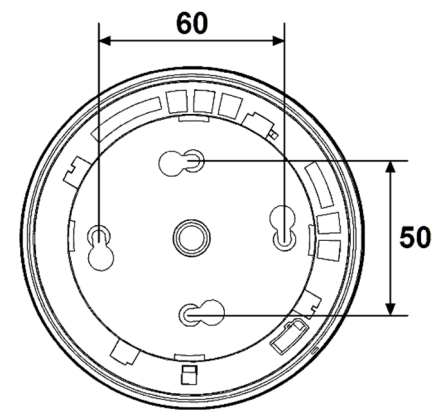

INDICATION

The device has a LED which indicates its state according to the following rules:

LED indication	Device's state
No indication or green flashes	Standby mode
Yellow flashes every 4 seconds	Fault state – low battery or malfunctioning smoke sensor
Red flashes every 2 seconds	Fire alarm

When the device is powered up, an automatic calibration process will begin, this lasts around one minute and is indicated with a red flashing LED.

SMOKE SENSITIVITY

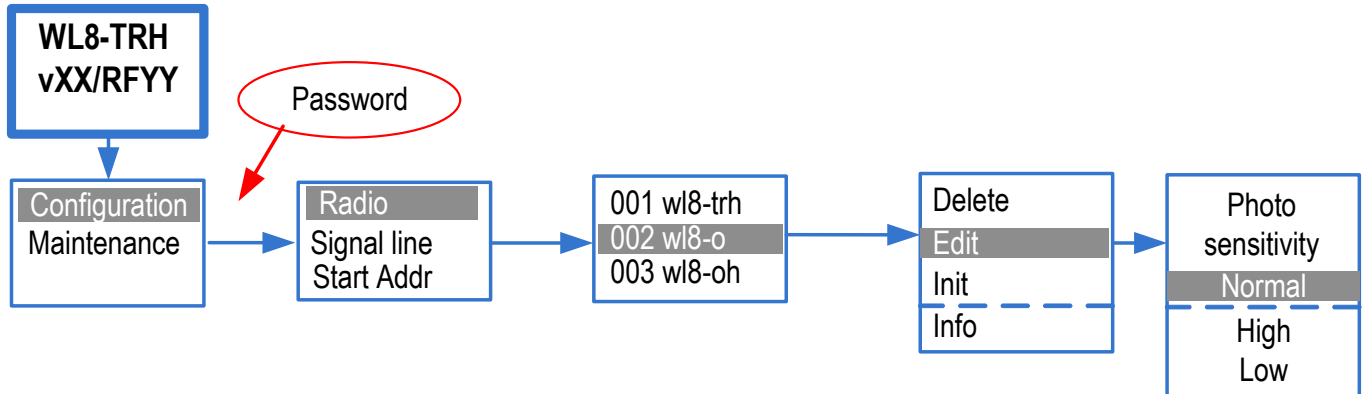

3 sensitivity options are available, these can be selected only by using the translator menu or the “Ekho Configuration” software (setting via the control panel will have no affect and sensor will remain in the selected mode).

TESTING

An alarm test can be performed with a magnet by placing it onto the outside of the sensor (opposite side to the base alignment marks) the sensor should take around 1 second to activate.

A suitable smoke test tool can also be used, please follow the instructions to apply smoke to the sensor in the correct way.

ANALOG DATA

The device provides the translator module with analog data about the current smoke level, air temperature, dust in the chamber and voltage levels on its batteries. This information can be viewed in the “Ekho Configuration” software.

Sensor	Partition	Primary supply	Standby supply	Temperature	Analog. type 1	An. value 1
3 WL8-O	003: Partition	3.1 V	3.3 V	25 °C	Smoke	31

By analyzing the voltage or dust levels, you can manage maintenance procedures and predict when you will have to replace the batteries or clean the smoke sensor. Please refer to the software manual for full instructions on how to use the program for system maintenance.



WARNINGS & LIMITATIONS

Devices use high quality electronic components and plastic materials that are highly resistant to environmental deterioration. However, after 10 years continuous operation it is advisable to replace them to reduce the risk of reduced performance caused by external factors. Ensure the devices are only used with compatible control panels. Detection systems must be checked, serviced and maintained on a regular basis to confirm correct operation.

Refer to and follow National Codes of Practice and other internationally recognized fire engineering standards. Appropriate Risk Assessment should be carried out initially to determine correct design criteria and updated periodically.

WARRANTY

All devices are covered by a 3-year limited warranty (does not apply to batteries). The warranty is voided by mechanical or electrical damage caused by incorrect handling or usage. Product must be returned via an authorized supplier for repair or replacement along with full information on the identified problem.

BATTERY REPLACEMENT

When a battery requires replacement, both batteries must be changed together.

- a. Remove the sensor from the base.
- b. Clip off the battery cover and remove the batteries.
- c. Insert the new batteries as detailed in the installation manual above – take care to observe + / - polarity.
- d. Re-fit the battery cover and re-insert the sensor into the base.
- e. Test the sensor in accordance with the manufacturer's instructions.

It is recommended to change both batteries after 10 years of operation regardless of their indicated discharge level.

To replace the batteries, use Panasonic CR123A (primary battery) and Varta CR2032 (secondary battery) or other with similar characteristics. The batteries must meet the following standards: UL 1642 lithium batteries, UL certified at www.ul.com or IEC 60086-4 Primary batteries, Part 4: Safety of lithium batteries.

The remaining shelf time of the new batteries must be not less than 8 years.



Failure to observe these instructions will void the device warranty and any liabilities.

CAUTION

- Replacement of a batteries must be of the same type.
- Do not expose used batteries to fire, hot ovens, or mechanical crushing/cutting as this can result in an explosion.
- Exposing batteries to extremely high environmental temperatures can result in explosion or the leakage of flammable liquid or gas.
- A battery subjected to extremely low air pressure may result in an explosion or the leakage of flammable liquid or gas.

DISPOSAL

- Follow local regulations regarding disposal of the batteries



EK-WL8-O
WIRELESS OPTICAL SMOKE SENSOR

STFV.425238.033-E-UM rev. 24

29.02.2024

Page 7 from 8

FOR TECHNICAL SUPPORT & PRODUCT RETURNS PLEASE CONTACT:

Grosvenor Road
Gillingham Business Park
Gillingham
Kent
ME8 0SA
United Kingdom
Tel: +44 (0)1634 260133

APPROVALS



1571b/01



2831-CPR-F4382



0832-UKCA-CPR-F1478

MANUFACTURING

ASI Oy Ltd
Finland, Savonlinna, Laitaatsillantie 3, 57170
Tel.: +358 408200991
E-mail: mail@asioy.fi
Web: www.asioy.fi



OTHER LANGUAGE VERSIONS OF THIS DOCUMENT:



Dutch (NL)



Spanish (ES)



Italian (IT)



German (DE)



Bulgarian (BG)