

CAB492W, CAB482W

Intelligent addressable wall visual alarm device (VAD)



A low-profile, low-current solution to the latest EN 54-23 fire standard.

A stylish, intelligent addressable fire alarm beacon, the visual alarm device (VAD) is for wall mounting and suitable for a variety of applications. It is available in a red body and compatible with a range of bases.

The VAD utilises Eaton's patented lens design that distributes light that efficiently. A weatherproof alternative with an IP66 ingress protection rating, making it suitable for wet and outdoor environments, is available.

Features and benefits

- Compliant to the latest standards (EN 54-23)
- Ultra-low current consumption
- Coverage switch - 7.5 m to 2.5 m
- Flash rate switch from 1 Hz to 0.5 Hz reduces power consumption by up to 50%
- Attractive, discrete design suitable for public places
- Variety of bases provides flexibility as to where the VAD can be installed
- Red (CAB482W) and white (CAB492W) flash options available



Powering Business Worldwide

Technical specification

Code	CAB492W, CAB482W
Mounting	Wall
Voltage	19–30 V
Current: stand-by	<330 μ A
Current: operating	12.5–45 mA (depending on setting and LED colour)
Mounting height (x)	2.4 m
Coverage (y)	Red flash : 7.5 m (switchable 2.48 m) White flash : 7.5 m (switchable 2.5 m)
Coverage volume code (c-x-y)	W-2.4-7.5
Flash rate	0.5 Hz (Switchable to 1 Hz)
Flash colour	Red and white
IP protection	Shallow base: IP33C Deep base: IP65
Operating temperature	Type A = -10°C – 55°C Type B = -25°C – 70°C

Standard connections

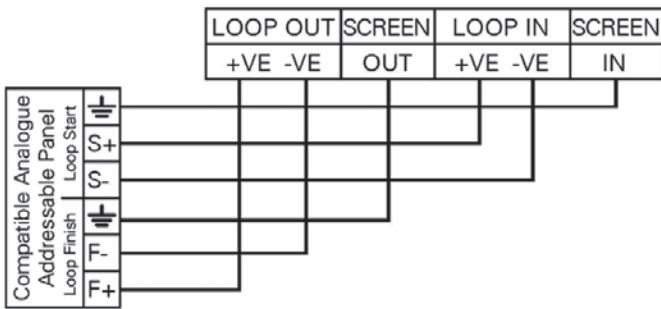

Warning:

Do NOT use high voltage testers if ANY equipment is connected to the system.

Earth screen must be continuous along entire length of the loop.

Dimensions

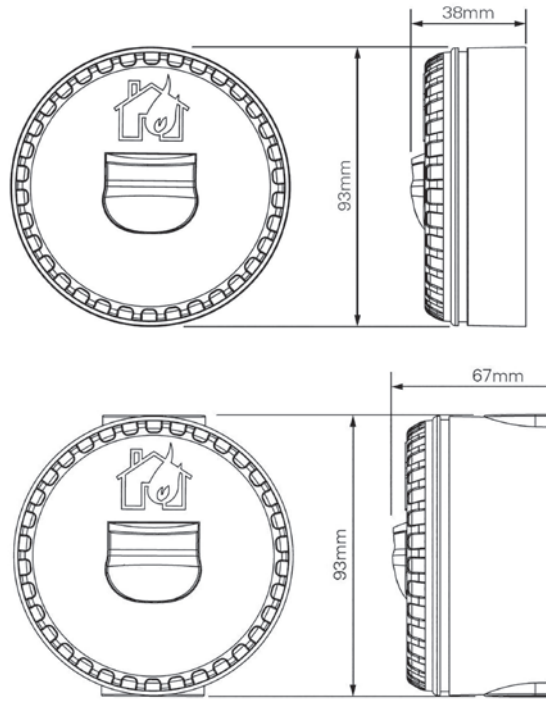

Description	H (mm)	W (mm)	D (mm)
Wall VAD (Shallow base)	93	93	38
Wall VAD (Deep base)	93	93	67

Catalogue numbers

Code	Reference	Description
CAB492WS	SOL-LX-W/WF/R1/S VAD EATON CAB492WS	Wall VAD, red, white flash, shallow base
CAB492WD	SOL-LX-W/WF/R1/WF/D VAD EATON CAB492WD	Wall VAD, red, white flash, deep base
CAB482WS	SOL-LX-W/RF/R1/S VAD EATON CAB482WS	Wall VAD, red, red flash, shallow base
CAB482WD	SOL-LX-W/RF/R1/D VAD EATON CAB482WD	Wall VAD, red flash, deep base

Note:

All information correct at the time of writing. Eaton reserve the right to make changes to this information. Please contact Eaton if you have any queries.

Eaton
EMEA Headquarters
Route de la Longeraie 7
1110 Morges, Switzerland
Eaton.com

© 2023 Eaton
All Rights Reserved
Publication No. DS0055-A
March 2023